



Suspension Control Module
32 221 0098
www.renntechmercedes.com

User Manual



ProgRama.

www.programainc.com

Designed and manufactured by ProgRama, Inc.

Marketed and distributed by RENNtech Inc,
Lake Park, FL, 561.845.7888
www.renntechmercedes.com

Read Before Installation

Warning:

This Lowering Module should be installed by an individual with extensive knowledge in electronics, including: wire identification, cutting, splicing, soldering and shrink wrap application.

RENNtech is not responsible for any damage to the Lowering Module or related devices due to improper installation.

Ride Height:

To retain proper ride comfort and to avoid damage to suspension components please follow these minimum recommended height adjustments.

All non-AMG Mercedes models should use a setting of 3 or higher.

AMG cars are lower than their Mercedes counterparts. With this in mind it is recommended that AMG cars use a ride height setting of 5 or higher.

Lower settings can be used for show purposes but are not recommended for everyday driving.

In some models the door must be closed in order for the Airmatic or ABC system to operate. This is a safety function and it is normal on those vehicles.

Technical Support:

For any further information, please contact RENNTech Inc. at 561-845-7888.

211 chassis	(E)	Airmatic	4-wire sensors	till 04/2006
219 chassis	(CLS)	Airmatic	4-wire sensors	till 04/2006

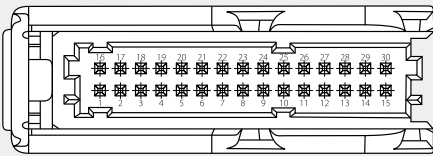
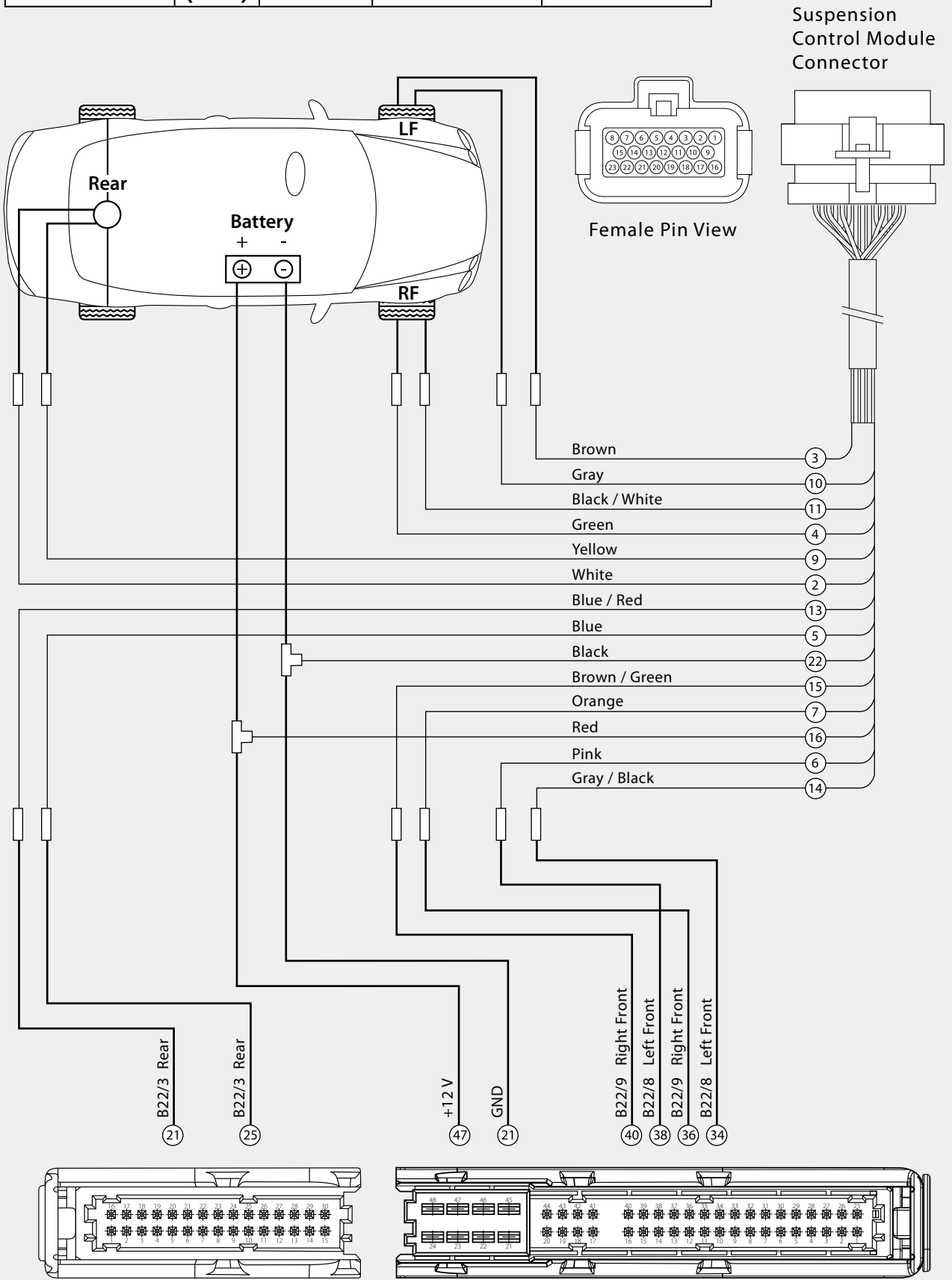

Airmatic Harness, Female Pin View

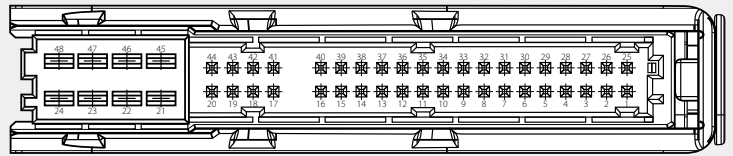

STEP-BY-STEP INSTALLATION

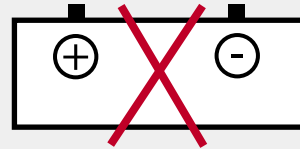

Disconnect the Battery



Right front upper footwell



Pull the carpet back

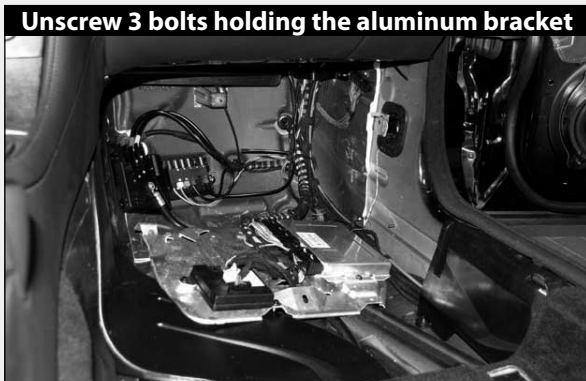

Unscrew 3 bolts holding the aluminum bracket



Airmatic (N51) with ADS

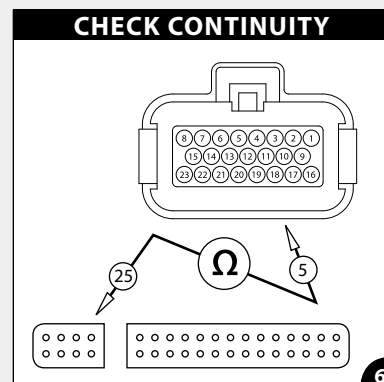
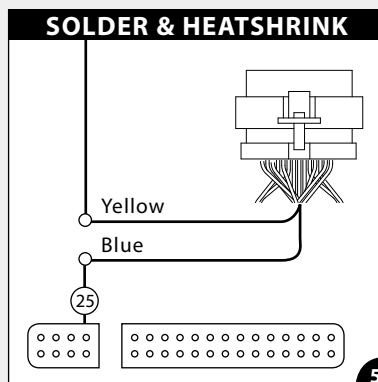
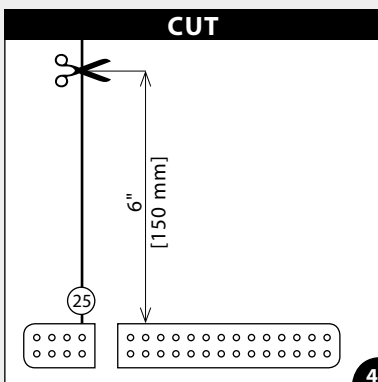
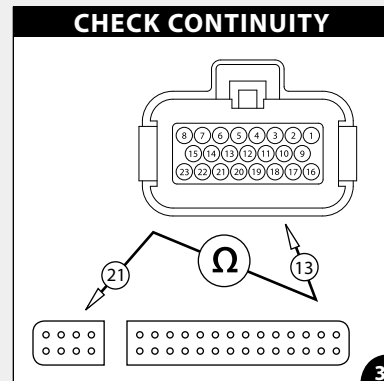
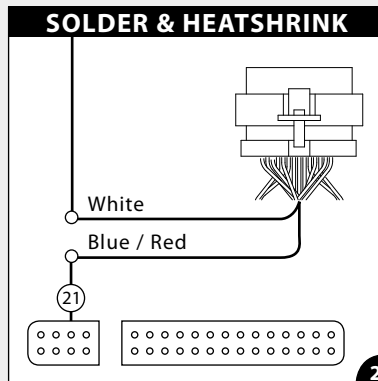
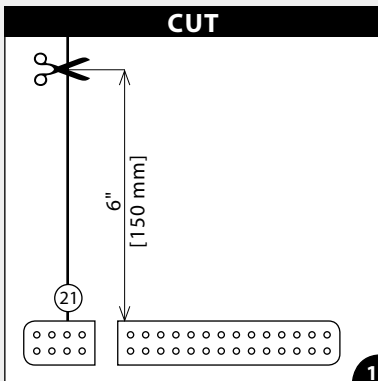

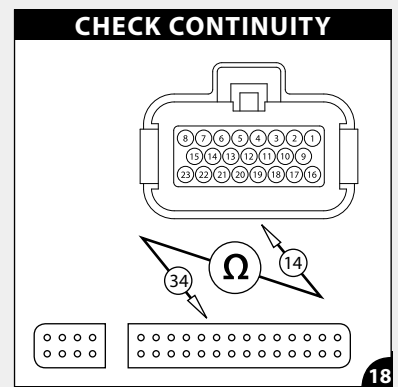
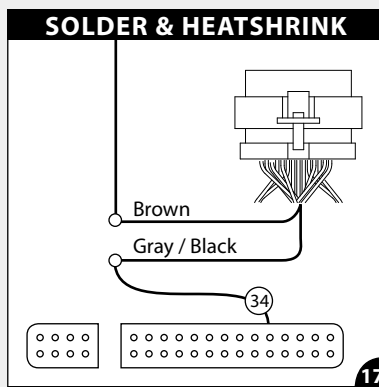
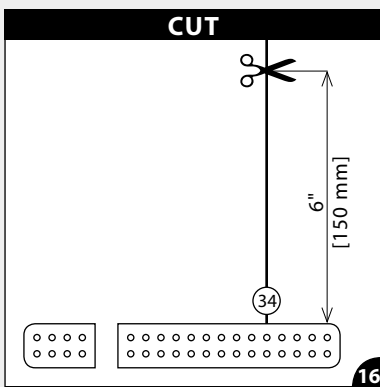
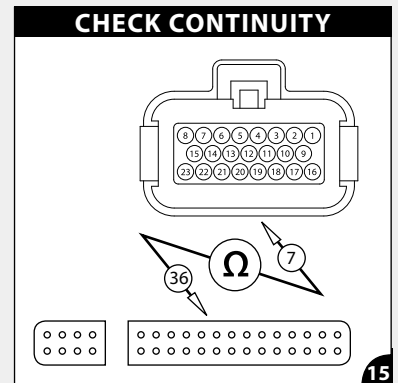
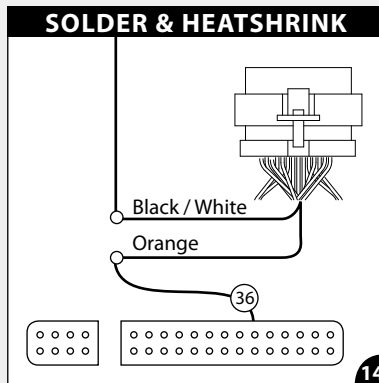
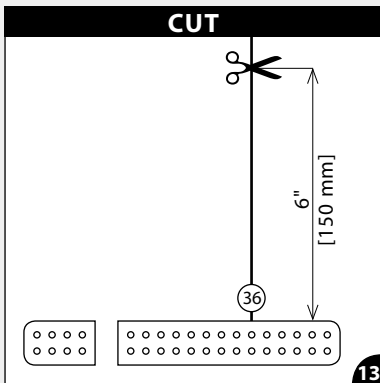
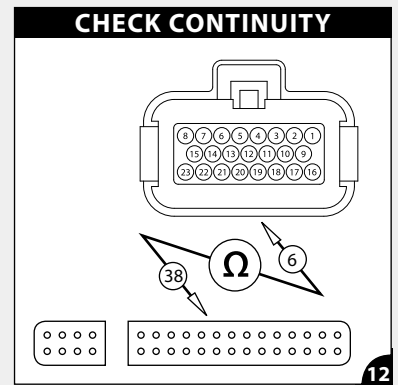
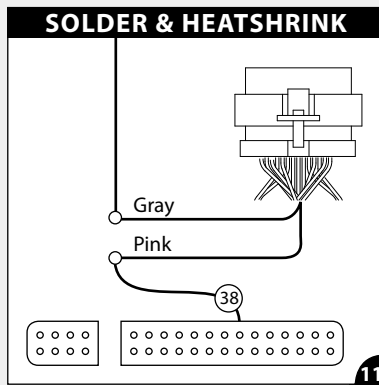
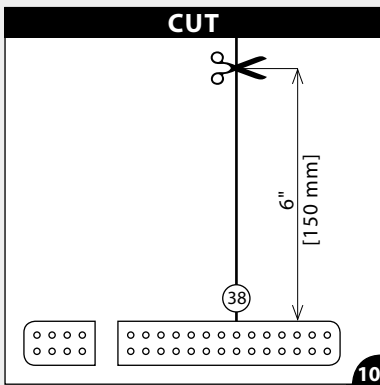
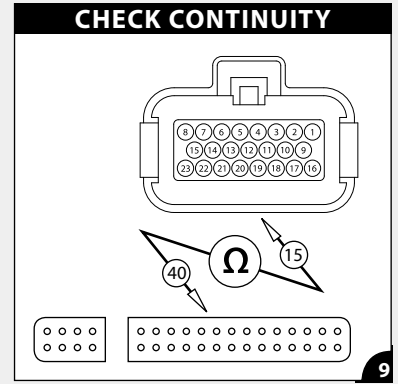
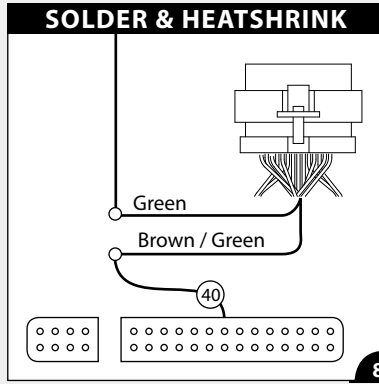
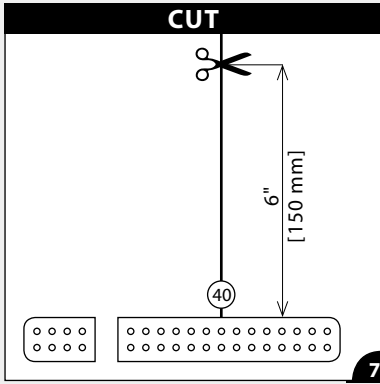

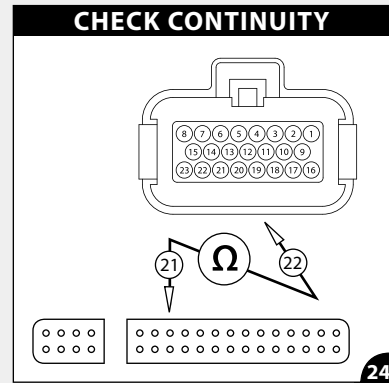
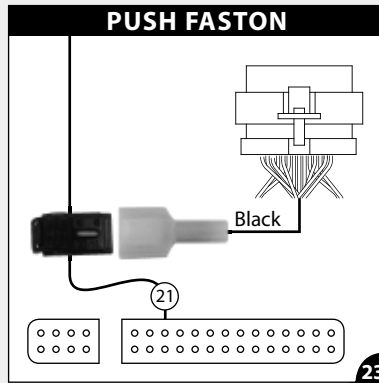
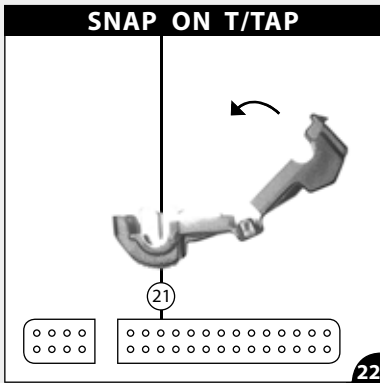
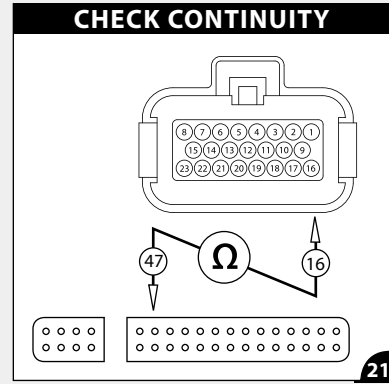
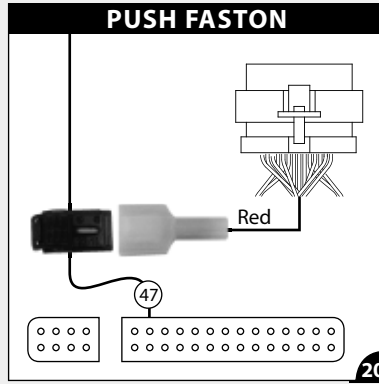
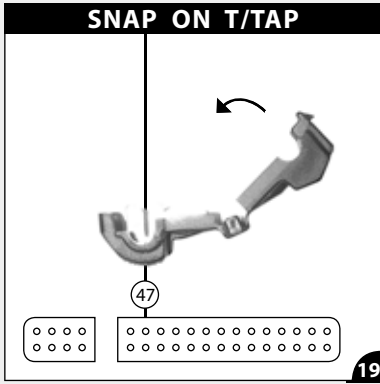

Unscrew the Suspension Module screws and remove the cover

25

Rotate the Function Switch (black button) to position 1

26

To continue, go to Height Adjustment chapter

27

Ride Height Adjustment

<p>Rotate all three Wheel Height Adjustment Switches (gray buttons) to position 3 (medium height).</p> <p>1</p>	<p>Plug in the RENNtech Suspension Module.</p> <p>2</p>	<p>Reconnect the battery. Green LED in the Suspension Module should blink.</p> <p>3</p>
<p>Cycle the ignition key On then Off (do not start the engine).</p> <p>4</p>	<p>Start the engine. Make sure you are parked on an even surface.</p> <p>5</p>	<p>Press the factory Vehicle Height button (button LED On). Wait up to 20 seconds until vehicle raises.</p> <p>6</p>
<p>Press the button again to lower the vehicle (button LED on the button will turn Off). Wait up to 20 seconds.</p> <p>7</p>	<p>Adjust individual Wheel Height Adjustment Switches if required (to see the height changing, perform the next step).</p> <p>8</p>	<p>Cycle the Vehicle Height button again (button LED On then Off), with up to 20 seconds in-between.</p> <p>9</p>
<p>If still not satisfied, go back to step 8.</p> <p>10</p>	<p>Replace the Suspension Module cover.</p> <p>11</p>	<p>Congratulations! The vehicle is lowered.</p> <p>12</p>

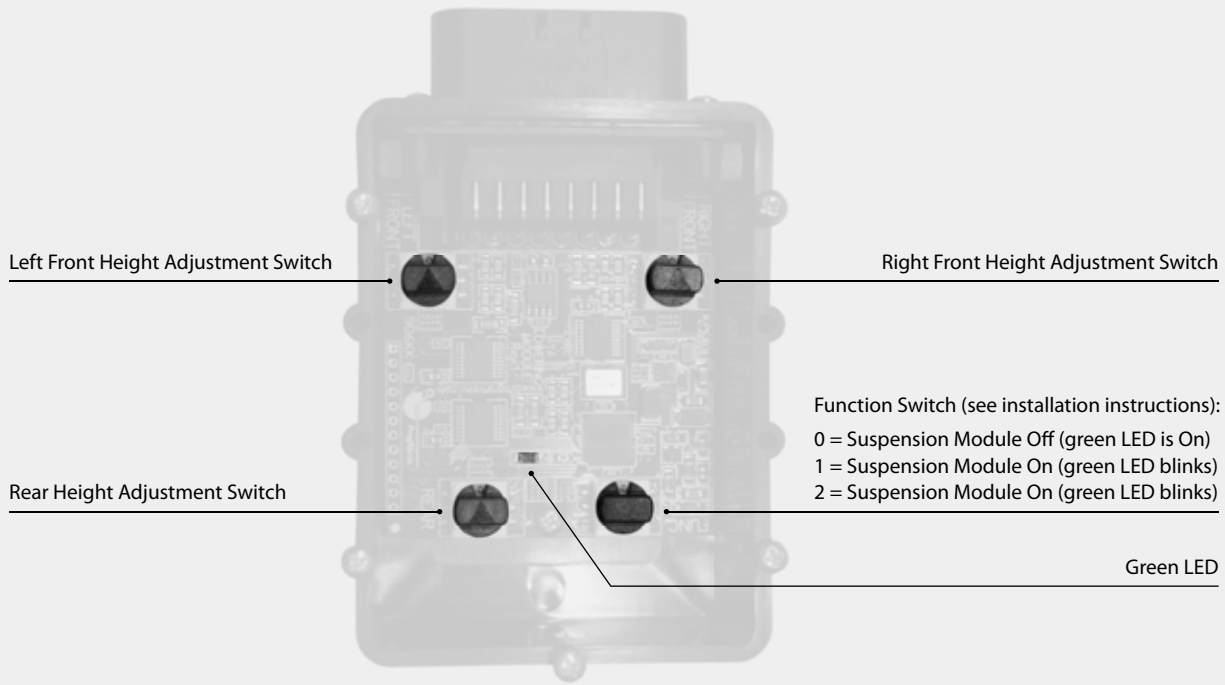

NOTES:

- It is quite common that even before the installation the individual wheels are not at the same level. This is much more noticeable when the vehicle is lowered. Small differences can be manually adjusted by rotating the individual Wheel Switches. Larger differences should be corrected at the dealer using proper equipment and procedure. Before going to the dealer, remember to turn off the RennTech Suspension Module by rotating the Function Switch (black button) to position 0. Once back from the dealer, rotate the Function Switch back to original position 1 or 2, as described in the Step-by-Step Installation.
- The pictured lowering values are approximate and will vary wheel to wheel and vehicle to vehicle:

Wheel Height Adjustment Switch positions

- 7: lower by 3/8" [10 mm]
- 6: lower by 3/4" [20 mm]
- 5: lower by 1" [25 mm]
- 4: lower by 1 1/8" [30 mm]
- 3: lower by 1 3/8" [35 mm]
- 2: lower by 1 1/2" [40 mm]
- 1: lower by 1 3/4" [45 mm]
- 0: lower by 2" [50 mm]

